



FOR LEASE

Brookhollow Business Park

7310-7340 Smoke Ranch Rd | Las Vegas, NV 89128



Property Highlights

- Price: \$0.85 NNN
- CAM: \$0.28
- ±1,424 - 3,089 SF available
- Office and Flex Warehouse suites available
- Zoned C-PB
- 14' to 21' clear height
- 120/208 volt, 3-phase
- Concrete tilt-up construction
- Air-conditioned offices and evaporative cooled warehouses
- 10'x12' Grade-level and dock loading doors
- Store-front entries
- Just off the US-95 and Lake Mead in the Mountain View medical district

Bob Hawkins
 +1 702 688 6959
 bob.hawkins@cushwake.com

6725 Via Austi Pkwy, Ste 275
 Las Vegas, NV 89119
 Main +1 702 796 7900
 Fax +1 702 796 7920
 cushmanwakefield.com



7310 | Suite D | 2,086 SF

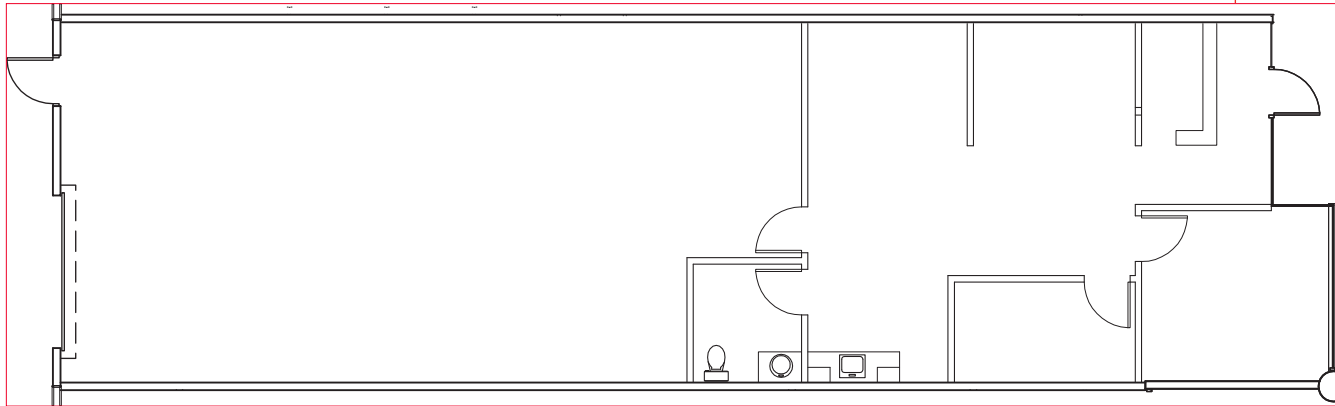

AVAILABLE FOR LEASE

Bldg	Bldg	Suite	SF
7310	A	D	2,086
7310	A	F	3,089
7320	B	F	2,006

Bob Hawkins
+1 702 688 6959
bob.hawkins@cushwake.com

6725 Via Austi Pkwy, Ste 275
Las Vegas, NV 89119
Main +1 702 796 7900
Fax +1 702 796 7920
cushmanwakefield.com

7310 | Suite F | 3,089 SF

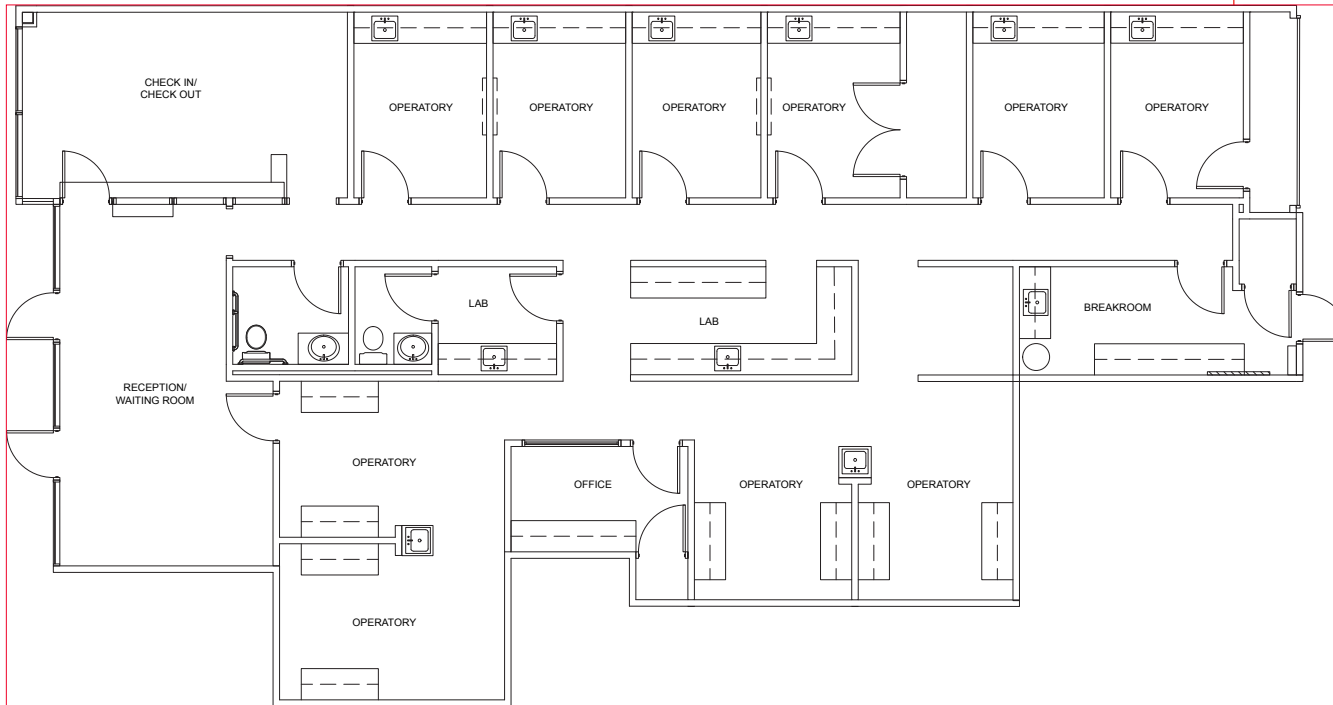

AVAILABLE FOR LEASE

Bldg	Bldg	Suite	SF
7310	A	D	2,086
7310	A	F	3,089
7320	B	F	2,006

Bob Hawkins
+1 702 688 6959
bob.hawkins@cushwake.com

6725 Via Austi Pkwy, Ste 275
Las Vegas, NV 89119
Main +1 702 796 7900
Fax +1 702 796 7920
cushmanwakefield.com

7320 | Suite F | 2,006 SF

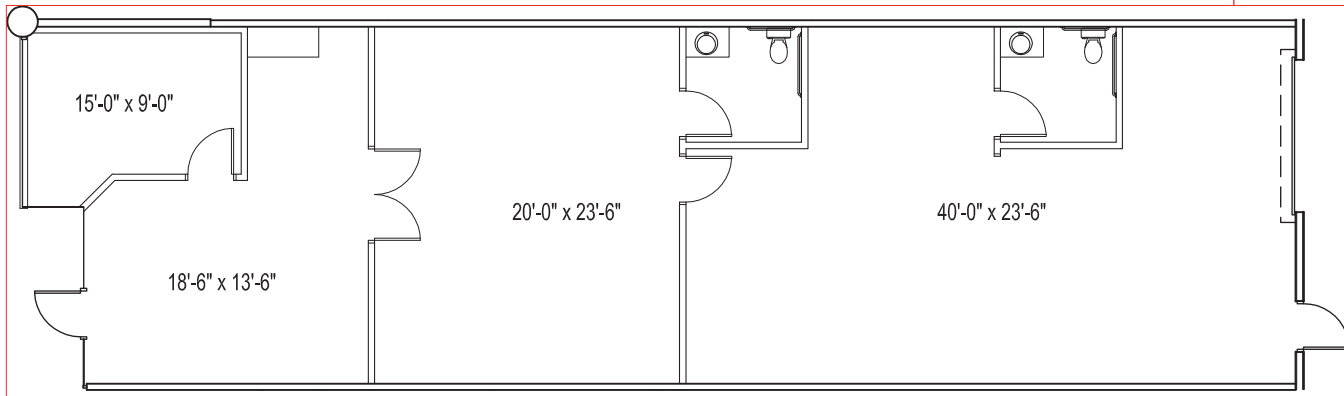

AVAILABLE FOR LEASE

Bldg	Bldg	Suite	SF
7310	A	D	2,086
7310	A	F	3,089
7320	B	F	2,006

Bob Hawkins
+1 702 688 6959
bob.hawkins@cushwake.com

6725 Via Austi Pkwy, Ste 275
Las Vegas, NV 89119
Main +1 702 796 7900
Fax +1 702 796 7920
cushmanwakefield.com